

**THETA DIGITAL**

**Dreadnaught III owner's manual**





## PREFACE

### CONGRATULATIONS

You have just acquired the most advanced and versatile component for the amplification of audio ever to have been developed.

### IMPORTANT

Save all packaging in a dry place away from fire hazards. Your Dreadnaught III is a precision electronic instrument and should be properly packaged any time shipment is made. In the unlikely event that you have to return your Dreadnaught III to the factory for service, or if you send it to us for updating, the original packaging will best protect the unit from shipping damage.

In order to achieve the fullest flexibility and enjoyment from your Dreadnaught III, we at Theta recommend that you read this manual in full before connecting the unit to your audio/video system.

**Note:** It is imperative that the Dreadnaught III be operated in a well-ventilated environment and the immediate external temperature be maintained as specified. External cooling fans may be required in some cases. Do not stack any equipment directly above or below the Dreadnaught III to protect it from overheating, as well as the continued functionality of any equipment near and around it.

**Warning:** Each channel is a balanced bridge amplifier, thus the negative speaker terminal is **NOT** a ground, and cannot be connected to a system ground or a loudspeaker system with a common ground. Consult your speaker manufacturer to ensure that any speaker in your system that will be connected to the Dreadnaught III does **NOT** have internal circuitry with a common ground.

### WARNING

United States law prohibits disposition of these commodities to Libya, Laos, North Korea, Cambodia or Cuba unless otherwise authorized by the United States.

© 2002-09 Theta Digital. All rights reserved.

This manual is also available for download as a PDF file at Theta Digital's website. <http://www.thetadigital.com>

No part of this publication may be reproduced or transmitted in any form or by any means, electronic or mechanical, for any purpose, without the express written permission of Theta Digital.

	<b>CAUTION</b> RISK OF ELECTRICAL SHOCK DO NOT OPEN	
CAUTION: TO REDUCE THE RISK OF ELECTRICAL SHOCK, DO NOT REMOVE COVER (OR BACK) NO USER-SERVICABLE PARTS INSIDE REFER SERVICING TO QUALIFIED SERVICE PERSONNEL		

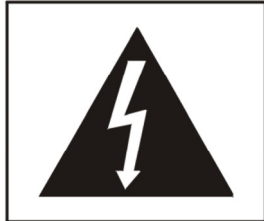

The lightning flash with arrowhead symbol, within an equilateral triangle, is intended to alert the user to the presence of uninsulated “dangerous voltage” within the product’s enclosure that may be of significant magnitude to constitute a risk of electric shock to persons.



The exclamation point within an equilateral triangle is intended to alert the user to the presence of important operating and maintenance (servicing) instructions in the literature accompanying the product.

## WARNING

**TO REDUCE THE RISK OF FIRE OR ELECTRIC SHOCK,  
DO NOT EXPOSE THIS PRODUCT TO RAIN OR MOISTURE**

---

CAUTION: TO PREVENT ELECTRIC SHOCK, DO NOT USE THE AC (POLARIZED) PLUG WITH AN EXTENSION CORD, RECEPTACLE OR OTHER OUTLET UNLESS THE BLADES CAN BE FULLY INSERTED TO PREVENT BLADE EXPOSURE.

---

Extension cords are not recommended for use with this product.

# Dreadnaught III Identification Record

This information is for your records and for future identification of the Dreadnaught III. Please take a moment to fill out all pertinent data now, and as upgrades and/or options are installed. **Whenever upgrades, inquiries and/or changes are requested, the serial number will be required.**

SERIAL NUMBER \_\_\_\_\_

DATE PURCHASED \_\_\_\_\_

DEALER'S NAME \_\_\_\_\_

DEALER'S ADDRESS/PHONE \_\_\_\_\_

INSTALLED CARDS/OPTIONS \_\_\_\_\_  
*(Date of installation)*

\_\_\_\_\_  
*(Date of installation)*

\_\_\_\_\_  
*(Date of installation)*

\_\_\_\_\_  
*(Date of installation)*

\_\_\_\_\_  
*(Date of installation)*

\_\_\_\_\_  
*(Date of installation)*

\_\_\_\_\_  
*(Date of installation)*

## **SAFETY PRECAUTIONS**

Please carefully read each item of the operating instructions and safety precautions before installing and using this product. Use extra care to follow the warnings written on the product itself and/or in the operating instructions. Keep the operating instructions and safety precautions for future reference.

**CAUTION: TO REDUCE THE RISK OF ELECTRICAL SHOCK, DO NOT REMOVE ANY OF THE COVER PANELS.**

**NO USER-SERVICEABLE PARTS INSIDE. REFER ALL SERVICING TO QUALIFIED SERVICE PERSONNEL ONLY.**

**TO PREVENT FIRE OR SHOCK HAZARD, DO NOT ALLOW LIQUIDS TO SPILL OR OBJECTS TO FALL INTO ANY OPENINGS OF THE PRODUCT.**

**THIS UNIT IS SUPPLIED WITH A 3 PIN GROUNDED AC PLUG. ALWAYS INSERT THE AC PLUG INTO A GROUNDED OUTLET. DO NOT REMOVE THE GROUND PIN OR DISABLE THE GROUND FOR ANY PURPOSE.**

**BEFORE MAKING ANY CONNECTIONS TO THE DREADNAUGHT III, FIRST TURN OFF THE POWER AND THEN DISCONNECT THE AC POWER CORD.**

**WHEN INSTALLING THE DREADNAUGHT III IN YOUR SYSTEM, MAKE CERTAIN TO ALLOW A MINIMUM OF ½ INCH OF VENTILATION ON EACH SIDE OF THE UNIT. ALSO ALLOW AT LEAST 3 INCHES OF VENTILATION SPACE ABOVE THE UNIT. IMPROPER VENTILATION OF THE UNIT MAY CAUSE OVERHEATING, WHICH MAY DAMAGE THE UNIT AND CAUSE A FIRE. PLACE THE UNIT ON A SOLID SURFACE ONLY. I.E. NOT ON CARPET, ETC.**

**DO NOT PLACE THE DREADNAUGHT III NEAR HEAT SOURCES SUCH AS DIRECT SUNLIGHT, STOVES, HEAT REGISTERS, RADIATORS OR OTHER HEAT PRODUCING EQUIPMENT.**

**TO PREVENT DAMAGE TO THE ANALOG OUTPUT CIRCUITRY, BE CERTAIN NOT TO SHORT THE OUTPUT SIGNAL TO GROUND. ENSURE THAT YOUR AUDIO OUTPUT CABLES DO NOT HAVE ANY INTERNAL SHORTS BEFORE CONNECTING THEM TO THE DREADNAUGHT III.**

**IF REPLACEMENT OF THE AC LINE FUSE AND/OR ANY INTERNAL FUSE BECOMES NECESSARY, REPLACE ONLY WITH SAME VALUE AND TYPE OF FUSE. NEVER BYPASS THE FUSE.**

**IF THE AC CORD BECOMES DAMAGED, DO NOT USE IT. IMMEDIATELY REPLACE IT WITH A NEW ONE OF THE SAME OR BETTER RATING.**

**IT IS IMPERATIVE THAT THE DREADNAUGHT III BE OPERATED IN A WELL VENTILATED ENVIRONMENT AND THE IMMEDIATE EXTERNAL TEMPERATURE BE MAINTAINED AS SPECIFIED. EXTERNAL COOLING FANS MAY BE REQUIRED IN SOME CASES. DO NOT STACK ANY EQUIPMENT DIRECTLY ABOVE OR BELOW THE DREADNAUGHT III AS TO PROTECT IT FROM OVERHEATING, AS WELL AS THE CONTINUED FUNCTIONALITY OF ANY EQUIPMENT NEAR AND AROUND IT.**

**EACH CHANNEL IS A BALANCED BRIDGE AMPLIFIER, THUS THE NEGATIVE SPEAKER TERMINAL IS NOT A GROUND, AND CANNOT BE CONNECTED TO A SYSTEM GROUND OR LOUDSPEAKER SYSTEM WITH A COMMON GROUND. CONSULT YOUR SPEAKER MANUFACTURER TO ENSURE THAT ANY SPEAKER IN YOUR SYSTEM THAT WILL BE CONNECTED TO THE DREADNAUGHT III DOES NOT HAVE INTERNAL CIRCUITRY WITH A COMMON GROUND.**

### **AFTER MARKET and THIRD PARTY MODIFICATIONS**

Please note that any after market and/or third party modifications will void the warranty. In the case of changing the feet on a unit, in order to prevent any damage (which will also not be covered under warranty), please verify that the screws being used to secure non-Theta feet do not screw any deeper into the chassis than the original ones. The original screw is 1/4-20 by 1/2 and goes into the chassis 1/4 inch.

## Table of Contents

PREFACE .....	ii
<b>WARNING</b> .....	<b>iii</b>
Dreadnaught III Identification Record .....	iv
SAFETY PRECAUTIONS .....	v
INTRODUCTION .....	1
Getting to know your Dreadnaught III .....	1
Burn-In Time .....	1
Reference Manual Conventions .....	1
<b>IMPORTANT NOTICE</b> .....	<b>2</b>
Dreadnaught III Block Diagram .....	3
Front Panel Layout .....	5
Front Panel Layout - Rackmount Option .....	6
Rear Panel Layout .....	7
OPERATION .....	9
Single and Two channel Modules .....	9
Remote Triggers .....	9
RS-232 .....	9
Appendix A    Troubleshooting Guide .....	10
Appendix B    Wiring Diagram .....	11
Appendix C    RS-232 Protocol .....	12
RS-232 Jumper Settings .....	15
Appendix D    Specifications .....	16

# INTRODUCTION

## Getting to know your Dreadnaught III

This Dreadnaught III has been put through a rigorous and unique testing procedure that ensures that it will last for many years with minimal service requirements. This procedure includes the following:

- All assembled circuit boards are given a thorough visual inspection and are then tested in a bench-reference Dreadnaught III.
- The tested, assembled circuit boards are then installed in a new Dreadnaught III and the whole unit is tested for every function and parameter.
- The unit is put on a burn-in torture rack to test for any possible component failures.
- It is then tested on an audio analyzer for all pertinent parameters.
- The unit has all remaining chassis components installed and then undergoes a complete visual inspection, which assures that all Dreadnaught III's meet visual specifications.
- The Dreadnaught III then undergoes a critical listening and functional test.

## Burn-In Time

This unit has a break in period of about 1 week during which continuous improvement in sound quality will be observed. It is recommended that music be played continuously through the unit during this time to expedite the break in period.

## Reference Manual Conventions

For clarity purposes, references to buttons and LED's will be shown in bold capital letters.

## IMPORTANT NOTICE

- I. It is imperative that the Dreadnaught III be connected to a ground via its three wire AC power cord. It is important that the AC power outlet, which the Dreadnaught III is plugged into, is actually grounded. Failure to do so will severely compromise the performance, reliability and safety of use of the Dreadnaught III.
- III. Ventilation is an important issue when placing the Dreadnaught III in a system. Make certain that the Dreadnaught III is placed in a well-ventilated area or rack unit.
- IIII. Please take note that some powerline conditioners defeat the AC power ground on their outlets. If the intention is to plug the Dreadnaught III into a line conditioner, check with your dealer to make certain that the particular conditioner that is intended for use DOES NOT DEFEAT THE AC GROUND on its AC outlets. Only the highest powered line conditioners should be considered for use with the Dreadnaught III. Otherwise, the amplifier's power output may be compromised.
- IV. DO NOT remove any cover panels from the Dreadnaught III, as there are no user serviceable components inside. Refer servicing and updating to qualified service personnel only.
- V. Endcaps on all unused RCA inputs will improve the sound quality and may reduce the susceptibility to RF induced anomalies.
- VI. It is imperative that the Dreadnaught III be operated in a well ventilated environment and the immediate external temperature be maintained as specified in Appendix D of this manual. External cooling fans may be required in some cases. Do not stack any equipment directly above or below the Dreadnaught III, to protect it from overheating, as well as the continued functionality of any equipment near and around it.
- VIII. Each channel is a balanced bridge amplifier, thus the negative speaker terminal is **NOT** a ground, and cannot be connected to a ground or a loudspeaker system with a common ground. Consult your speaker manufacturer to ensure that any speaker in your system that will be connected to the Dreadnaught III does **NOT** have internal circuitry with a common ground.

# Dreadnaught III Block Diagram

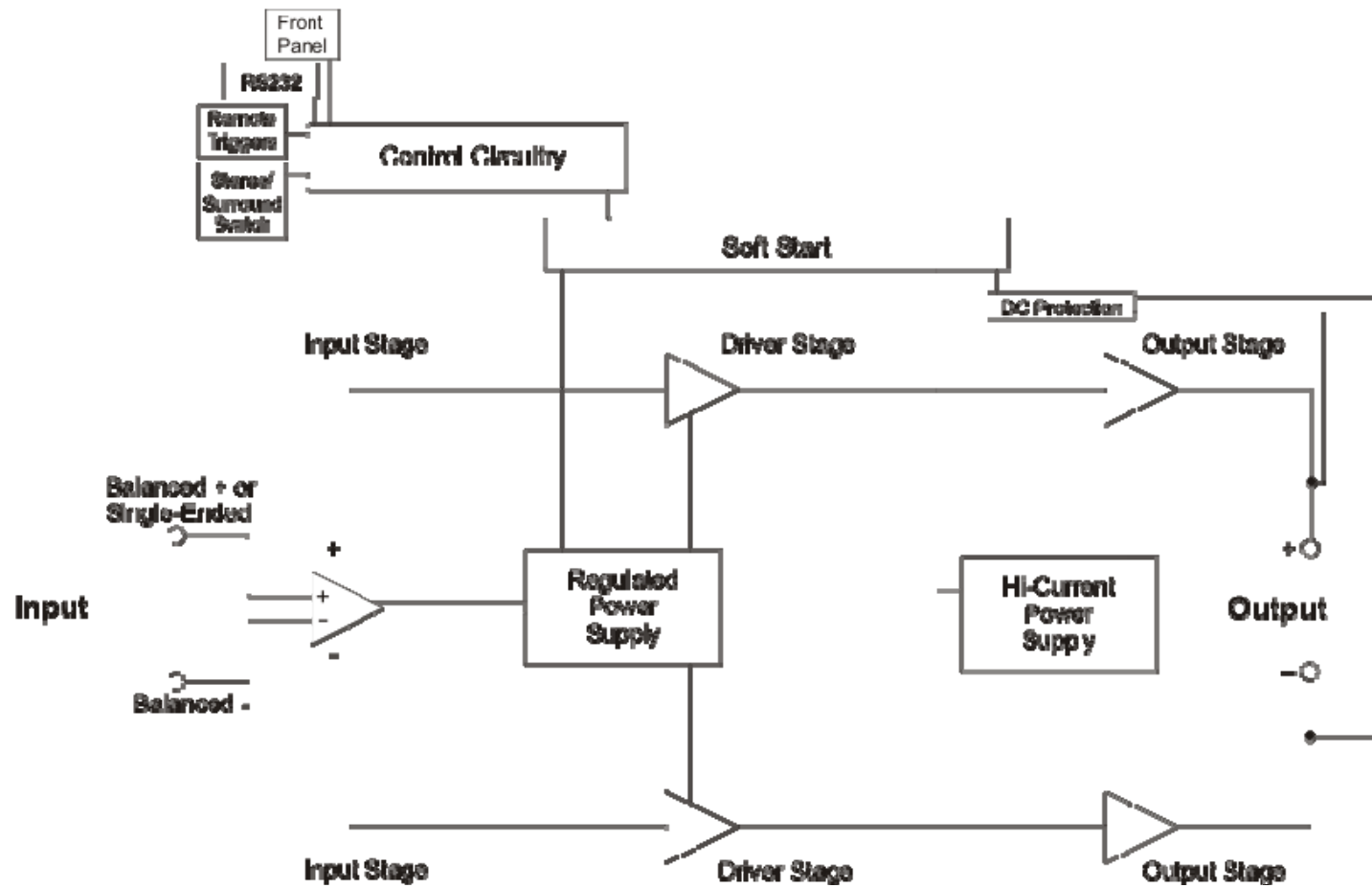

Figure 1 - Block Diagram (Dreadnaught III showing single channel module)

Dreadnaught III Block Diagram con't.

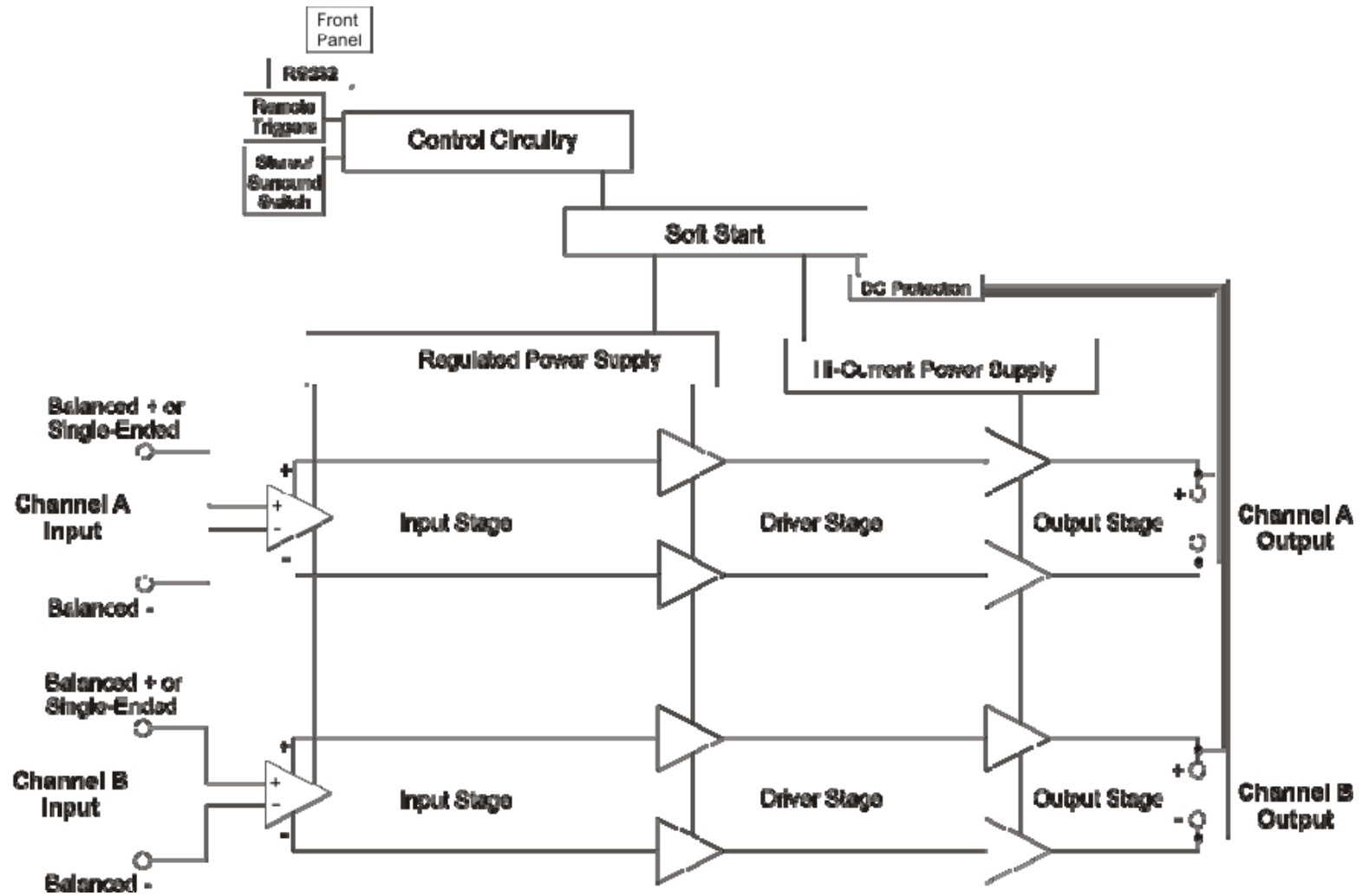

Figure 2 - Block Diagram (Dreadnaught III showing two channel module)

## Front Panel Layout

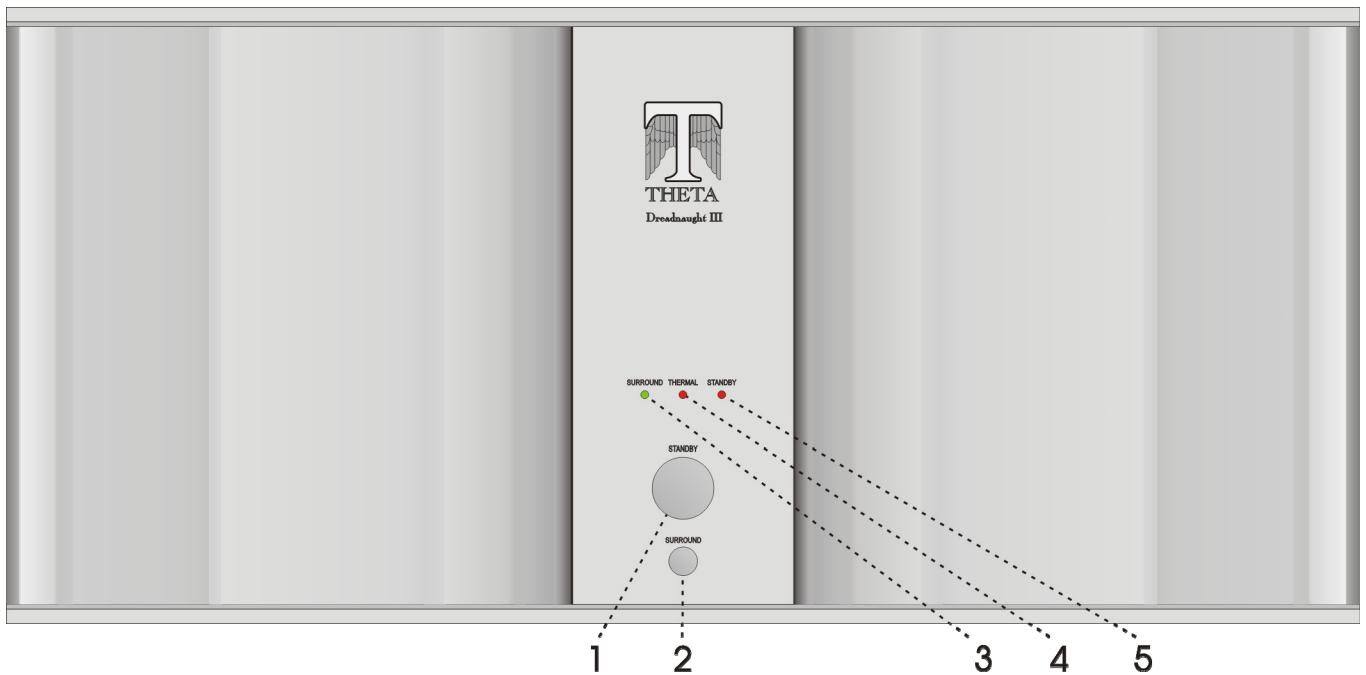
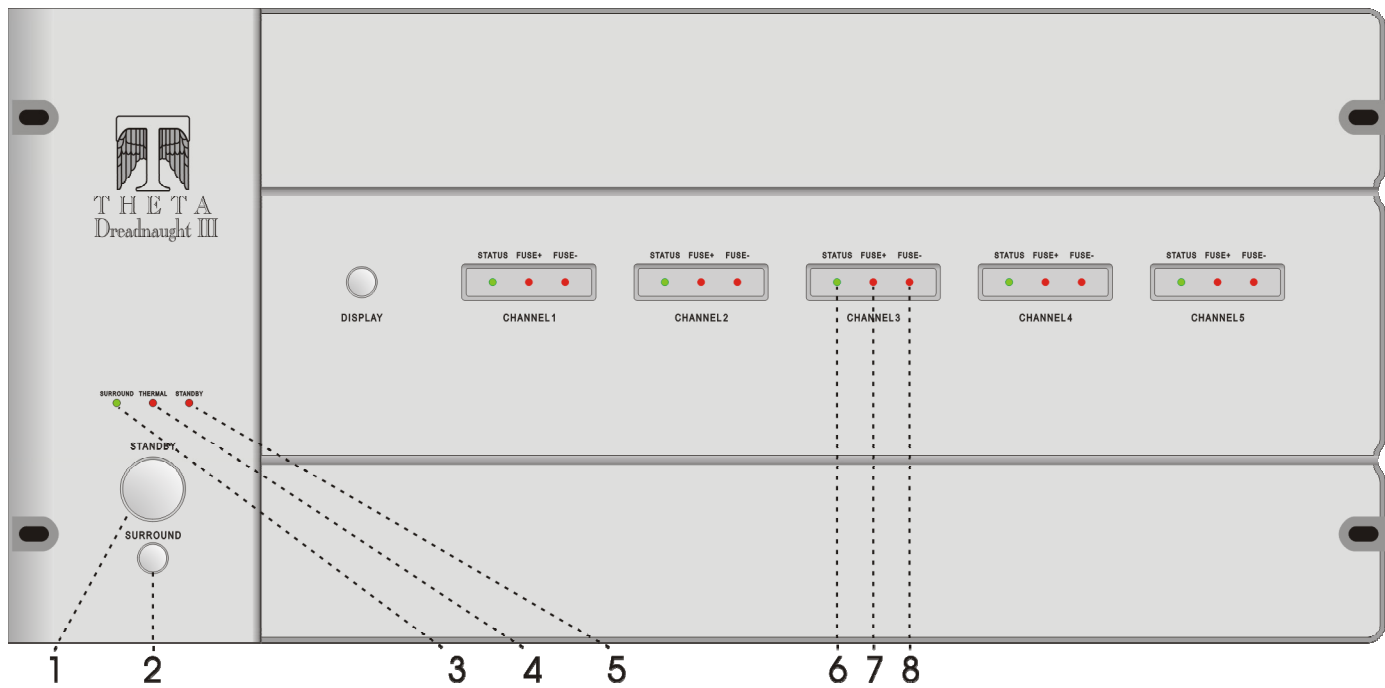

Figure 3a - Front Panel Layout

1. **STANDBY** button. After the rear panel **MAIN POWER** switch is turned on press the front panel **STANDBY** button to exit the standby mode. All channels on the stereo bus will come out of standby. If the surround bus is active, with specific channels assigned to it, they will exit the standby mode as well.
2. **SURROUND** button. Activates/deactivates the **SURROUND** bus.
3. **SURROUND** LED. Illuminates when the surround bus is active.
4. **THERMAL** LED. Illuminates when any channel's temperature rises above the maximum operating temperature.
5. **STANDBY** LED. Illuminates red when the power amplifier is in **STANDBY**, green when the amplifier is active.

## Front Panel Layout - Rackmount Option



**Figure 3b - Rackmount Front Panel Layout**

1. **STANDBY** button. After the rear panel **MAIN POWER** switch is turned on press the front panel **STANDBY** button to exit the standby mode. All channels on the stereo bus will come out of standby. If the surround bus is active, with specific channels assigned to it, they will exit the standby mode as well.
2. **SURROUND** button. Activates/deactivates the **SURROUND** bus.
3. **SURROUND** LED. Illuminates when the surround bus is active.
4. **THERMAL** LED. Illuminates when any channel's temperature rises above the maximum operating temperature.
5. **STANDBY** LED. Illuminates red when the power amplifier is in **STANDBY**, green when the amplifier is active.
6. **Channel STATUS** LED.           When OFF, indicates that there is no Amp module installed  
  When GREEN, indicates module is present  
  When RED, indicated module is overheating
7. **FUSE+** LED. When on, indicates that the + (plus) rail fuse is blown.
8. **FUSE-** LED. When on, indicates that the - (minus) rail fuse is blown.

## Rear Panel Layout

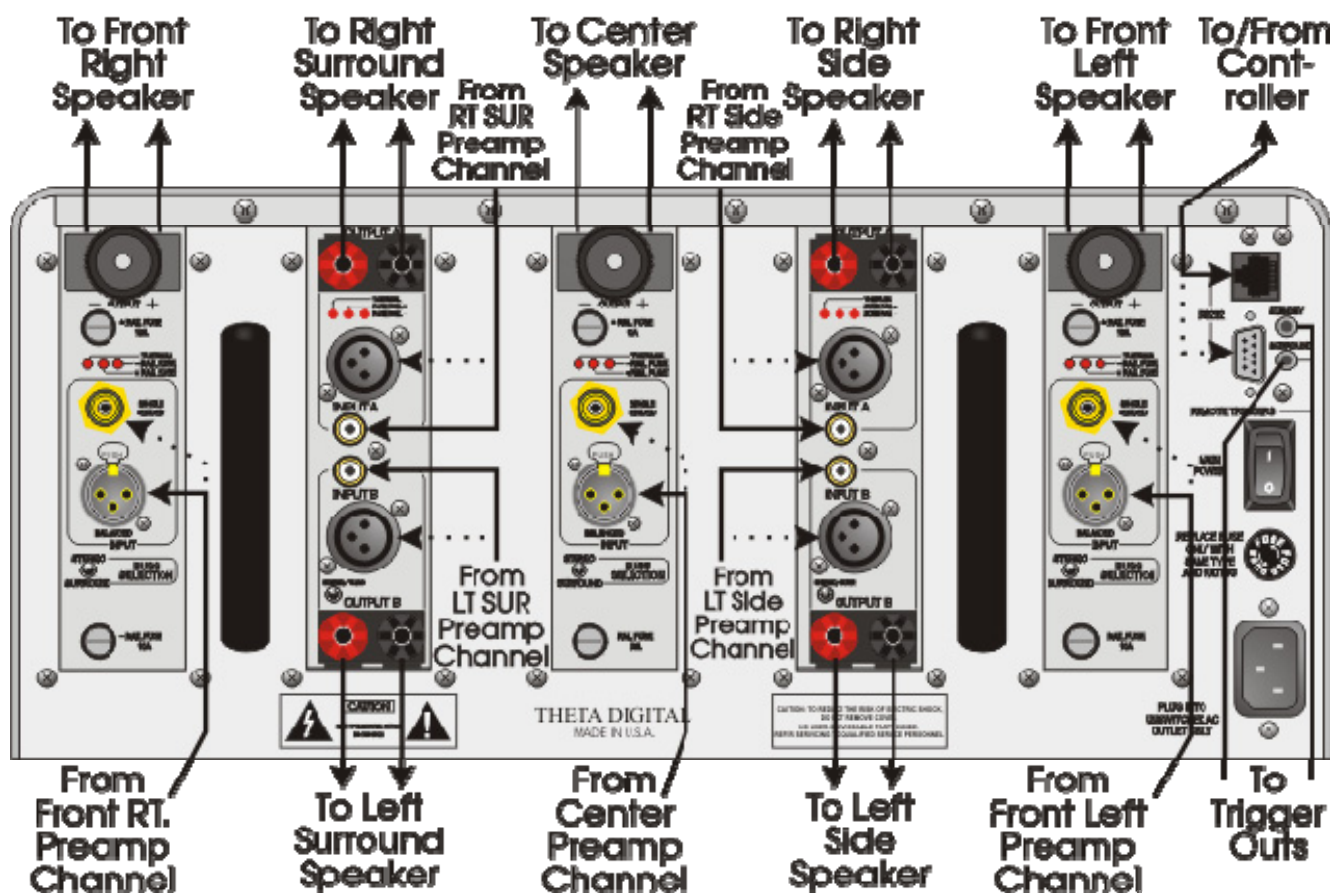

Figure 4 - Rear Panel Layout showing both single and two channel modules installed

1. Channel **THERMAL LED**. Illuminates when the channel rises above the maximum operating temperature. The Dreadnaught III should be powered off and cooled when this LED is lit.
2. Channel **RAIL FUSE + LED**. When this LED is illuminated, the fuse on the positive rail of the channel is blown. (Internal on 2 channel modules).
3. + Module **RAIL FUSE**. If necessary to replace, use only same type and rating.
4. **BINDING POST**. (Single Channel module). Connect plus and minus speaker wires for one speaker to appropriately marked terminals of each post. The binding post on the single channel module will operate optimally using spade lugs.
5. Channel **RAIL FUSE LED**. When this LED is illuminated, an internal fuse on the negative rail of the channel is blown. (Internal on 2 channel modules).
6. **SINGLE-ENDED** input jack on single channel module.
7. **STEREO/SURROUND** buss selector switch. Assigns the module to either the **STEREO** or **SURROUND** buss.
8. - Module **RAIL FUSE**. If necessary to replace, use only same type and rating.
9. **BALANCED** input jack on single channel module.
10. **POSITIVE BINDING POST** - Channel A. (Two channel module). Connects to the + (plus) speaker connector. The binding posts on the two channel module can accept spade lugs, banana plugs or bare wire.
11. **NEGATIVE BINDING POST** - Channel A. (Two channel module). Connects to the - (minus) speaker connector.
12. **BALANCED** input jack - Channel A of two channel module.

13. **SINGLE-ENDED** input jack - Channel A on two channel module.
14. **POSITIVE BINDING POST** - Channel B. (Two channel module). Connects to the + (plus) speaker connector. The binding posts on the two channel module can accept spade lugs, banana plugs or bare wire.
15. **NEGATIVE BINDING POST** - Channel B. (Two channel module). Connects to the - (minus) speaker connector.
16. **STEREO/SURROUND** bus selector switch. Assigns the affected module (both channels) to either the **STEREO** or **SURROUND** buss.
17. **BALANCED** input jack - Channel B of two channel module.
18. **SINGLE-ENDED** input jack - Channel B on two channel module.
19. **SURROUND REMOTE TRIGGER** jack. When the rear panel **SURROUND TRIGGER** jack receives a change in the 12V (0V to 12V or 12V to 0V) the amp's surround mode will change from its current status, either on or off.
20. **DB9 RS-232** connector. Used for connecting a system control device to the Dreadnaught III to control and monitor its functions.
21. **RJ45 RS-232** connector. See DB9 RS-232 connector, above.
22. **STANDBY REMOTE TRIGGER** jack. When the rear panel **STANDBY TRIGGER** jack receives a change in the 12V (0V to 12V or 12V to 0V) the amp's standby mode will change from its current status, either on or off.
23. **MAIN POWER Switch**. Master power switch. Disconnects AC to all circuits. It is recommended that this be left ON at all times during regular use with the exception of whenever cables are connected/disconnected or when the unit is not going to be used for an extended period of time.
24. Rear panel **FUSE**. If necessary to replace, use same type and rating only.
25. **AC POWER INPUT**.

## OPERATION

Before turning on the Dreadnaught III, ensure that all precautions and warnings have been carefully reviewed and adhered to. Damage to the Dreadnaught III caused by improper operation, wiring and/or ventilation will not be covered under warranty and Theta will not be liable for any consequential damage or loss.

After the main rear power switch is turned on, the amp goes into Standby. The amplifier is completely off now, save a very small (and low power) supply to activate the new soft start circuit. When the Standby button is pressed, a soft start sequence begins and the LED turns amber. One relay click will be heard after about 1 second, and then another after about 5 seconds, after which the LED will go green and the amp will be fully on. Pressing the Standby button again takes the amp directly into full (new) standby as described above. This amp is green!

As for the new DC Protect circuit, if any significant DC is detected on any channel, the amp will immediately go into Standby, AND it will remain there - one must turn off the rear main power switch, then turn it back on again, to reset the amp. This has the intent of allowing one find what caused the DC.

The two front panel buttons operate independently. The **STANDBY** button toggles between standby and operate. When in standby, the front panel **STANDBY LED** will be red and when out of standby, this same LED will be green. The **SURROUND** button activates/deactivates the channel(s) that been assigned to the surround buss via their rear panel switch. When the surround buss is active, the **SURROUND LED** on the front panel will illuminate green. When the surround buss is inactive, the front panel **SURROUND LED** will be off. The surround buss may be turned on or off regardless of whether the unit is in standby or operate. The state of the surround buss is unaffected by the standby state.

Each module can be assigned to operate on either the **STEREO** or **SURROUND** buss. When the Dreadnaught III has more than two modules installed in it, it is recommended that the front left and right channels be set to **STEREO** and all remaining channels be set to **SURROUND**, via the rear panel **STEREO/SURROUND** switch. In the **STEREO** mode (front panel **SURROUND LED** off), any channels set to the **STEREO** buss will operate. In the **SURROUND** mode (front panel **SURROUND LED** illuminates green), all channels will operate.

### Single and Two channel Modules

The Dreadnaught III can be loaded with any combination of modules. Those available are single (mono) and two channel (stereo) modules. Each module can be set to operate individually on the stereo or surround buss.

**Note:** The speaker output polarity on the single channel module is reversed compared to the two channel module. The maximum spade lug thickness for the two channel module is 1/16”

### Remote Triggers

Installed are both Standby and Surround triggers that accept both 12V steady state trigger type and pulse type. Amps now leave the factory with the remote trigger board set to 12V trigger type. The 12V state is a toggle switch. Changes in voltage from 0 to 12 and from 12 to 0 will activate the trigger. Use a 1/8” (3.5mm) mono plug for these jacks. To make the remote trigger board respond appropriately to a pulse type trigger instead, it is necessary to shift a jumper from pins 2-3 to 1-2 of the J3 on the remote trigger board. **This change must be done by an authorized Theta Digital dealer or representative, or the warranty of the unit will be voided.**

### RS-232

RS-232 is an option in the Dreadnaught III. It can be installed at any time either at the factory or an authorized Theta dealer. All functions of the Dreadnaught III can be controlled and monitored via RS-232, using either the RJ45 or DB9 connector. As long as the rear panel power switch is turned on, the RS-232 circuitry is always active, thus allowing the Dreadnaught III to be taken out of **STANDBY** via RS-232.

## Appendix A Troubleshooting Guide

If the Dreadnaught III should function abnormally during operation, please review the items in the following checklist. Please be sure to thoroughly check all other connected components such as speakers, preamplifiers, as well as cables.

Symptom	Possible Cause(s)	Remedy
No power or front panel lights and no sound.	Power cable is not inserted 100% into AC input connector.	Ensure that the AC cord is inserted all the way into the Dreadnaught III and that the wall outlet is active.
	Rear panel fuse is open.	Replace with same type and rating ONLY.
	Circuit breaker is open (AC outlet).	Check the AC outlet circuit breaker and reset, if necessary, or contact your dealer.
No audio output.	STEREO/SURROUND switch not set correctly.	Verify all switch settings to ensure that a given channel is assigned to the correct buss.
	SURROUND buss is off, or in standby	Press the front panel SURROUND button once. The SURROUND LED should be illuminated green.
	Overheating	If the front panel THERMAL LED is illuminated, shut down the Dreadnaught III until it cools. An external fan may be necessary.
	Plus or minus fuse is open.	Check the rear panel fuse indicator LEDs. If one is on, an internal fuse is open.
Hot/Warm	Normal operation	

## Appendix B Wiring Diagram

This section provides an example illustration of an input and output wiring scheme. In this example, the Dreadnaught III has 3 single channels and two 2 channel modules installed. Before making any connections, please turn off ALL audio and video devices. Unplug those that do not have a main power switch. It is recommended that all cables, including speaker cables be kept as short as possible for best sound quality.

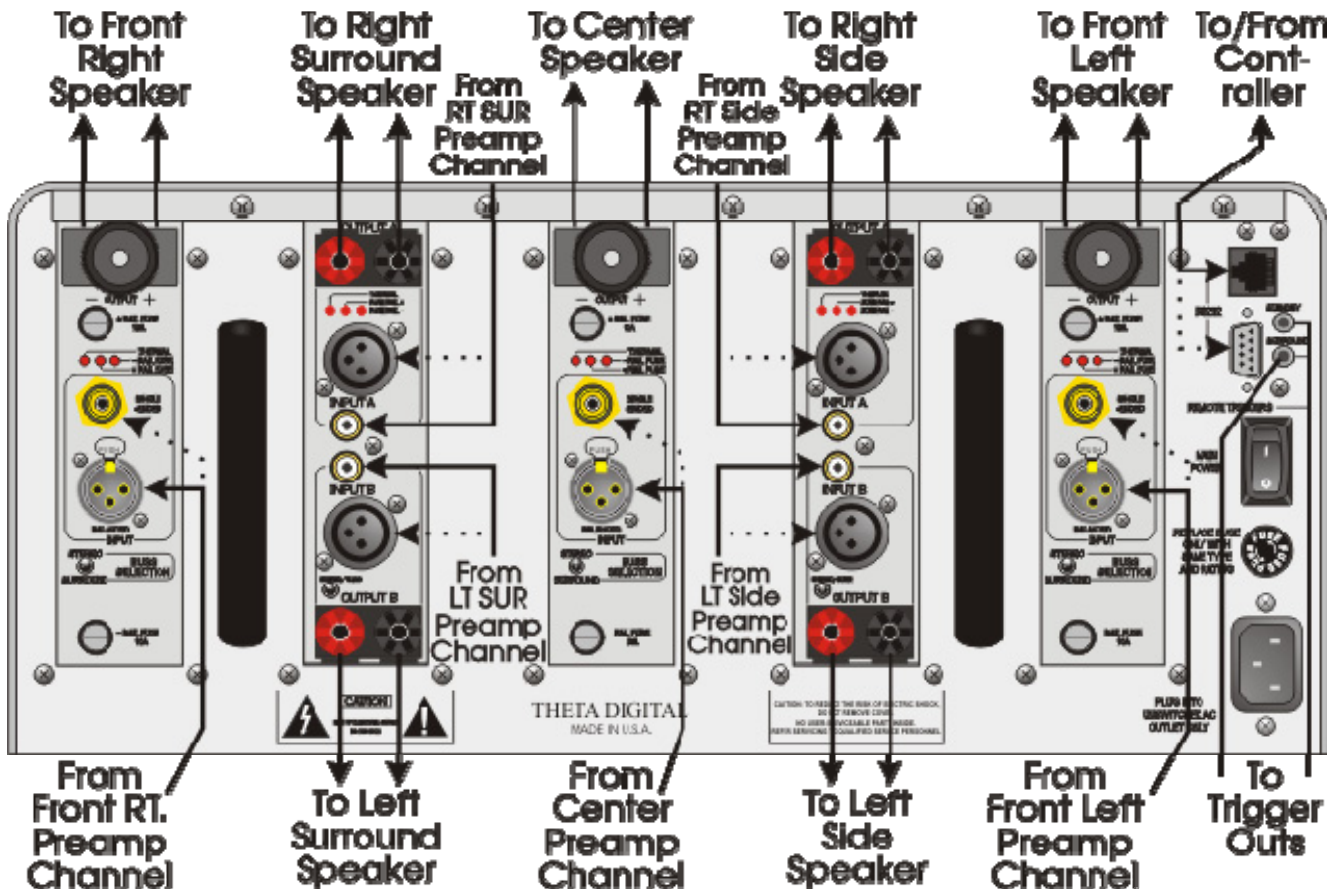

Figure 5 - Examples of Typical Input and Output Connections

----- = optional connection.

**WARNING:** Each channel is a balanced bridge amplifier, thus the negative speaker terminal is NOT a ground, and cannot be connected to a ground or a loudspeaker system with a common ground. Consult your speaker manufacturer to ensure that any speaker in your system that will be connected to the Dreadnaught III does NOT have internal circuitry with a common ground. Damage will occur if the negative terminal is connected to ground, or to a terminal of another channel or module.

## Appendix C RS-232 Protocol

RS-232 settings are internally definable via jumper blocks, to accommodate interfacing with a wide range of control products.

Baud rate	9600 or 19200
Echo status	AUTO or REQUEST

**Baud rate:** Maximum number of bits per second. The duration of a single bit is equal to 1 / baud rate.  
**Echo status:** Specifies whether the **STATUS** of each parameter shown in the protocol will automatically (**AUTO**) be echoed back to the controller when there is any change, or whether the user must manually request (**REQ**) the status information be sent to the controller. Please refer to page 15 or information on changing these settings.

All commands will follow the format:

<Header><Command Identifier><Argument 1><Argument 2><Argument 3>  
where:

<Header> = <FEh><E8h> (254 232)  
<Command identifier> = <byte>  
<Argument x> = <byte>

Each command will be able to access the system configuration directly, eliminating the need to press any button on the Dreadnaught III's front panel.

Examples:

- 1) To select put the Dreadnaught III into standby: Send FE, E8, 01, 00, 00, 00 (all values in Hex).  
Where FE and E8 are the header, 01 = command, 00 = main standby, 00 = put unit in standby and 00 = filler (4 characters required)
- 2) To activate the Surround buss: Send FE, E8, 01, 01, 01, 00  
Where FE and E8 are the header, 01 = command, 01 = surround buss, 01 = activate surround buss and 00 = filler (4 characters required)

Command	Description	Argument 1	Argument 1 Description	Argument 2	Argument 2 Desc	Argument 3	Arg 3 Desc
01	Standby	0	Main standby	0	Put unit in standby		
		0	Main standby	1	Take unit out of standby.		
		1	Surround bus	0	Make surround bus inactive.		
		1	Surround bus	1	Activate surround bus.		
02	Status	0	Return amplifier status.				
The RS-232 can be set using a hardware jumper to automatically send changes to the RS-232 port.							
Status Byte #	Byte Description	bit	Value Description				
1	Bus	0	Main bus				
		1	Surround bus				
2	Temperature	0	Channel 1				
		1	Channel 2				
		2	Channel 3				
		3	Channel 4				
		4	Channel 5				
3	Fuse Plus Rail	0	Channel 1				
		1	Channel 2				
		2	Channel 3				
		3	Channel 4				
		4	Channel 5				
4	Fuse Minus Rail	0	Channel 1				
		1	Channel 2				
		2	Channel 3				
		3	Channel 4				
		4	Channel 5				
5	Channel Sense	0	Channel 1				
		1	Channel 2				
		2	Channel 3				
		3	Channel 4				
		4	Channel 5				

# RS-232 Hardware Connections

RTS and CTS are not implemented in Dreadnaught III

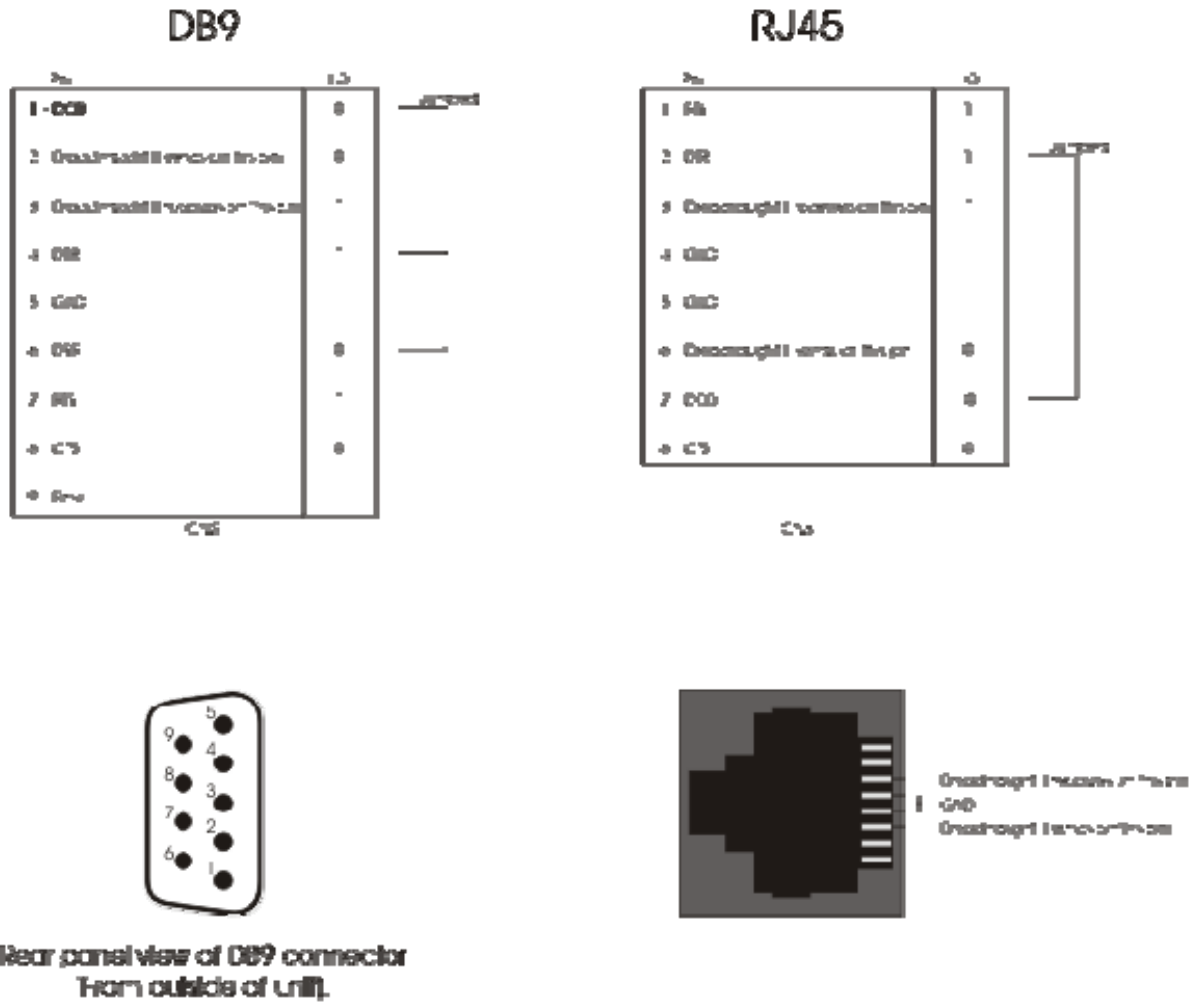

Figure 6 - Dreadnaught III RS-232 Jack Pinout

These are the connector drawings only. The RS-232 cable must be a regular RS-232 or mouse extender cable, wired pin for pin.

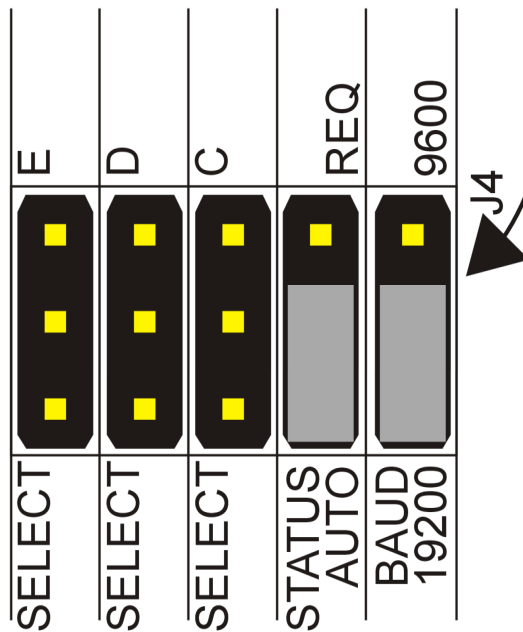
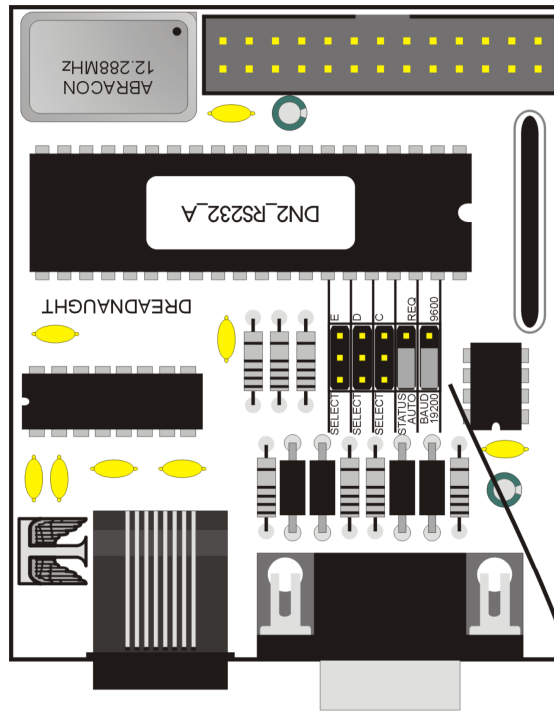

Figure 7 - Dreadnaught III RS-232 Jumper Settings

### RS-232 Jumper Settings

There are 2 possible Baud rates: **9600** and **19200**. The factory default is **19200**. To change the baud rate to **9600**, move the jumper to the center and top pins (if the RS-232 board is orientated as in figure 7).

The **STATUS** can be returned to the controller either: automatically every time a parameter has changed, or the user can request it manually. The factory default is **AUTO**. To set the Echo **STATUS** to return status information only upon request, move the **AUTO/REQ** jumper to the top pins, or nearer to **REQ** on the RS-232 board.

The three **SELECT** jumpers are not currently implemented.

## Appendix D Specifications

Input Impedance 50 Kohms. Single-Ended or Balanced, each phase, both modules.

**Input sensitivity**  
**Mono module:**  
Single-ended) 2.5V RMS input for 250W into 8 ohms.  
Balanced) 1.25V RMS input for 250W into 8 ohms.  
**Stereo module:**  
Single-ended) 1.5V RMS input for 100W into 8 ohms.  
Balanced) 0.75V RMS input for 100W into 8 ohms.

**Gain**  
**Mono Module:**  
(Single-Ended) 26dB (20x).  
(Balanced) 32dB (40x).  
**Stereo Module:**  
(Single-Ended) 25.5dB (19x).  
(Balanced) 31.5dB (38x).

**Polarity**  
(Single-ended) Non-Inverting.  
(Balanced) Pin-2 = Positive, Pin-3 = Negative for Non-Inverting Output.

### Analog Audio Outputs

1 balanced output per channel.

I / O RS-232 1 DB9 and 1 RJ45 connector.

Modes/Processes Standby, Stereo and Surround. Channels may be individually assigned to either buss.

**Power Output**  
**Mono Module:**  
(8 ohms-one channel driven) 250 W (rated) 325 W (typical)  
(8 ohms-five channels driven) 250 W (rated) 245 W 260 W (typical)  
(4 ohms-one channel driven) 450 W (rated) 475 W 525 W (typical)  
(2 ohms-one channel driven) 550 W (rated) 675 W (typical)  
(1 ohms-one channel driven) 720 W (typical)  
**Stereo module:**  
(8 ohms-one to ten channels driven) 100 W (rated) 115 W (typical)  
<(4 ohms-one channel driven) 200 W (rated) 210 W (typical)

Frequency Response (-3dB points @ full power) 0.3Hz - 250 kHz.

THD+Noise **Mono module:** <1%  
**Stereo Module:** <1.25% (both channels driven into 100W @ 8 ohms).

Signal to Noise Ratio (unweighted) >100dB

**Trigger Inputs:** 0V - 12V steady state or pulse (1mS - 500mS.) Units are set at factory for steady state trigger.

**Dimensions:** 17 5/8" W x 8 7/16" H x 23 1/2" D (448 x 214 x 597 mm) Regular front panel  
18 15/16" W x 9 1/16" H x 23" D (481 x 230 x 584) Rackmount front panel.

**Weight:** 98 Lbs. Stand alone (44.5 Kg), 111 Lbs. Boxed with accessories (50.4 Kg)

**Maximum Operating Temperature:** Internal: 176° F (80° C)  
Room: 122° F (50° C)

**90 DAY LIMITED WARRANTY TERMS AND CONDITIONS**  
(5 Year optional extended service contract)

1. Theta Digital, henceforth referred to as Theta, warrants the product designated herein to be free of manufacturing defects in material and workmanship, subject to the conditions set forth herein, for a period of 90 days from the date of purchase by the original purchaser, henceforth referred to as purchaser. If the purchaser registers the unit with Theta by mailing in the warranty card, together with a copy of the bill of sale, within 14 days of the date of purchase, said purchaser will be registered for an extended service contract. Product registration may also be completed by going to Theta Digital's website at [http://www.thetadigital.com/product\\_registration.asp](http://www.thetadigital.com/product_registration.asp). The extended service contract extends the 90 days to a period of 5 years from the date of purchase by the original purchaser or no later than 7 years from the date of shipment to the authorized Theta dealer, whichever comes first.
2. **CONDITIONS**  
This warranty is subject to the following conditions and limitations. The warranty is void and inapplicable if the product has been used or handled other than in accordance with the instructions in the owner's manual, abused or misused, damaged by accident or neglect or in being transported, or if the defect is due to the product being repaired or tampered with or modified by anyone other than Theta or an authorized Theta repair center. In the unlikely event that the unit requires service, contact Theta for an RA (Return Authorization) number. The product must be packed and returned to Theta or an authorized Theta repair center by the customer at his or her sole expense. Theta will pay return freight of its choice. A returned product must be accompanied by a written description of the defect, a photocopy of the original purchase receipt, and a daytime phone number where the owner can be reached. The unaltered receipt must clearly list model and serial number, the date of purchase, the name and address of the purchaser and authorized dealer and the purchase price. Theta reserves the right to modify the design of any product without obligation to purchasers of previously manufactured products and to change the prices or specifications of any product without notice or obligation to any person.
3. **REMEDY**  
In the event the above product fails to meet the warranty, and the above conditions have been met, the purchaser's sole remedy under the limited warranty shall be to obtain an RA number and return the product to Theta or an authorized Theta repair center where the defect will be rectified without charge for parts or labor.
4. **LIMITED TO ORIGINAL PURCHASER**  
This warranty is for the sole benefit of the original purchaser of the covered product and shall not be transferred to a subsequent purchaser of the product.
5. **DURATION OF WARRANTY**  
This warranty expires 90 days after the date of original purchase. If Theta receives the completed warranty registration card within 14 days of original purchase, this period is extended to the fifth anniversary of the original date of purchase or no later than the seventh anniversary of the shipment to the authorized Theta dealer, whichever comes first.
6. **MISCELLANEOUS**  
**ANY IMPLIED WARRANTIES RELATING TO THE ABOVE PRODUCT SHALL BE LIMITED TO THE DURATION OF THIS WARRANTY. THE WARRANTY DOES NOT EXTEND TO ANY INCIDENTAL OR CONSEQUENTIAL COSTS OR DAMAGES TO THE PURCHASER.** Some states do not allow limitations on how long an implied warranty lasts or an exclusion or limitation of incidental or consequential damages, so the above limitations or exclusions may not apply to you. This warranty gives you specific legal rights, and you may also have other rights which vary from state to state.
7. **WARRANTOR**  
Inquiries regarding the above limited warranty may be sent to the following address:

Theta Digital  
1749 Chapin Road  
Montebello CA 90640 USA

**WARRANTY OUTSIDE THE USA and Canada**

Theta has formal distribution in many of the countries of the free world, in each country the Theta Importer has contractually accepted the responsibility for product warranty. Warranty service should normally be obtained from the importing dealer or distributor from whom you obtained your product.

**WARNINGS**

1. To prevent fire or shock hazard, do not expose your Theta product to rain or moisture.
2. This unit contains voltages which can cause serious injury or death. Do not operate with covers removed. Refer all servicing to your authorized Theta dealer.
3. For continued protection against fire hazard, replace fuses only with the same type and rating of fuses as specified.